





PROTEM SAS ZI les Bosses F-26800 Etoile sur Rhone Tel.: +33 (0) 47557-4141 Fax: +33 (0) 47557-4149 www.protem.fr		  	PROTEM GmbH Am Hambiegel 27 D-76706 Dettenheim Tel.: +49 (0) 7247 9393-0 Fax: +49 (0) 7247 9393-33 www.protem-gmbh.de
ISO 9001	FT 00910	Toolbit TTNG	1/6

STANDARD TOOL BIT FOR TTNG

Rep.	Description	Machine	Maxi wall thickness	
O-TTN-TT1-5-H-F-PL	<i>Cutting tool bit</i>	TTNG	35 mm 1.378"	
O-TTN-TT1-5-H-F-PT	<i>Severing tool bit</i>	TTNG	35 mm 1.378"	
O-TTN-TT2-12-H-2	<i>30° beveling tool bit</i>	TTNG	27 mm 1.062"	
O-TTN-TT3-12-H-3	<i>37°30 beveling tool bit</i>	TTNG	20 mm 0.787"	
O-TTN-TT4-12-H-4	<i>45° beveling tool bit</i>	TTNG	15 mm 0.595"	
O-TTN-TT5-12-H-5	<i>30° reversed beveling tool bit</i>	TTNG	27 mm 1.062"	
O-TTN-TT6-12-H-6	<i>37°30 reversed beveling tool bit</i>	TTNG	20 mm 0.787"	

PROTEM SAS ZI les Bosses F-26800 Etoile sur Rhone Tel.: +33 (0) 47557-4141 Fax: +33 (0) 47557-4149 www.protem.fr		  	PROTEM GmbH Am Hambiegel 27 D-76706 Dettenheim Tel.: +49 (0) 7247 9393-0 Fax: +49 (0) 7247 9393-33 www.protem-gmbh.de
ISO 9001	FT 00910	Toolbit TTNG	2/6

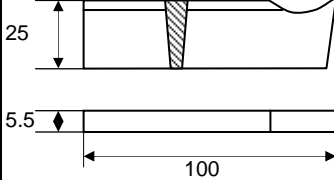
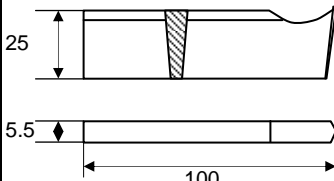
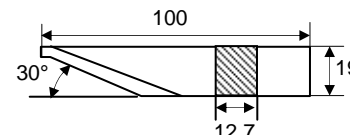
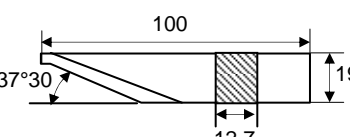
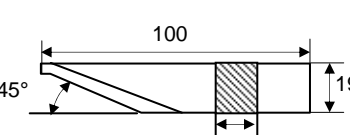
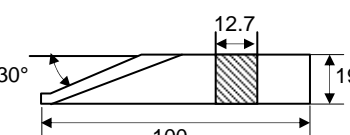
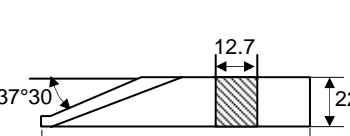
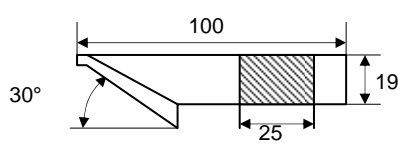
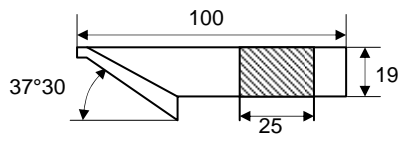
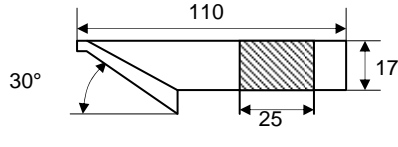
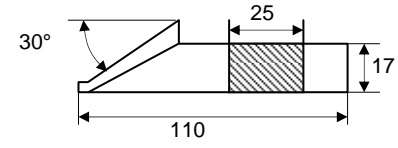
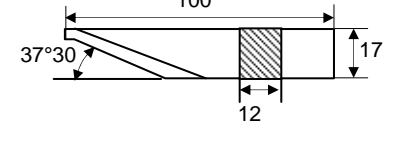
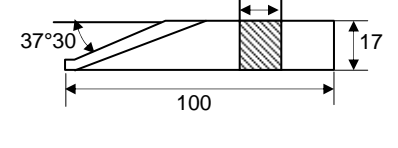
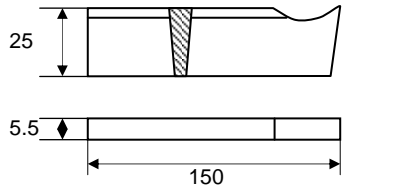
Rep.	Description	Machine	Maxi wall thickness	
O-TTN-TT7-25-H-7	<i>30° beveling tool bit</i>	TTNG	35 mm 1.378"	
O-TTN-TT8-25-H-8	<i>37°30 beveling tool bit</i>	TTNG	35 mm 1.378"	
O-TTN-TT9-25-H-9	<i>30° beveling tool bit for double bevel</i>	TTNG	35 mm 1.378"	
O-TTN-TT9I-25-H-9	<i>30° reversed beveling tool bit for double bevel</i>	TTNG	35 mm 1.378"	
O-TTN-TT10-12-H-10	<i>37°30 beveling tool bit for double bevel</i>	TTNG	18 mm 0.708"	
O-TTN-TT10I-12-H-10	<i>37°30 reversed beveling tool bit for double bevel</i>	TTNG	18 mm 0.708"	
O-TTN-TT11-5-H-PL	<i>Severing tool bit</i>	TTNG	90 mm 3.543"	

PROTEM SAS ZI les Bosses F-26800 Etoile sur Rhone Tel.: +33 (0) 47557-4141 Fax: +33 (0) 47557-4149 www.protem.fr		  	PROTEM GmbH Am Hambiegel 27 D-76706 Dettenheim Tel.: +49 (0) 7247 9393-0 Fax: +49 (0) 7247 9393-33 www.protem-gmbh.de
ISO 9001	FT 00910	Toolbit TTNG	3/6

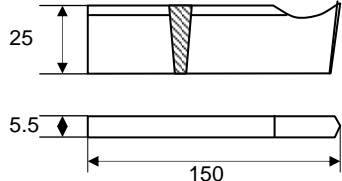
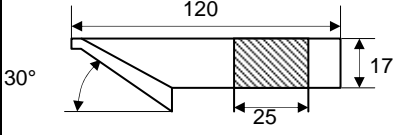
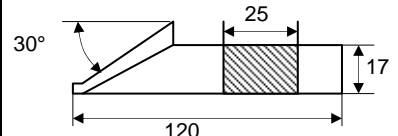
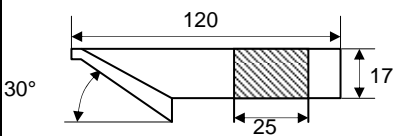
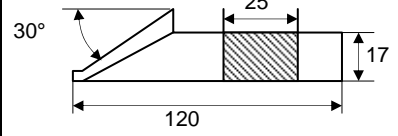
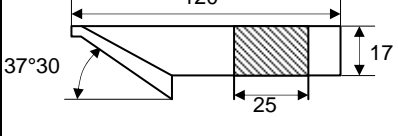
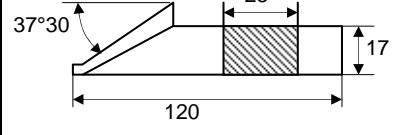
Rep.	Description	Machine	Maxi wall thickness	
O-TTN-TT11-5-H-PT	<i>Cutting tool bit</i>	TTNG	90 mm 3.543"	
O-TTN-TT12-25-H-12	<i>30° beveling tool bit for double bevel</i>	TTNG	46 mm 1.811"	
O-TTN-TT12I-25-H-12	<i>30° reversed beveling tool bit for double bevel</i>	TTNG	46 mm 1.811"	
O-TTN-TT13-25-H-13	<i>30° beveling tool bit for double bevel</i>	TTNG	39 mm 1.535"	
O-TTN-TT13I-25-H-13	<i>30° reversed beveling tool bit for double bevel</i>	TTNG	39 mm 1.535"	
O-TTN-TT14-25-H-14	<i>37°30 beveling tool bit</i>	TTNG	50 mm 1.968"	
O-TTN-TT14I-25-H-14	<i>37°30 reversed beveling tool bit for double bevel</i>	TTNG	50 mm 1.968 "	

PROTEM SAS ZI les Bosses F-26800 Etoile sur Rhone Tel.: +33 (0) 47557-4141 Fax: +33 (0) 47557-4149 www.protem.fr		  	PROTEM GmbH Am Hambiegel 27 D-76706 Dettenheim Tel.: +49 (0) 7247 9393-0 Fax: +49 (0) 7247 9393-33 www.protem-gmbh.de
ISO 9001	FT 00910	Toolbit TTNG	4/6

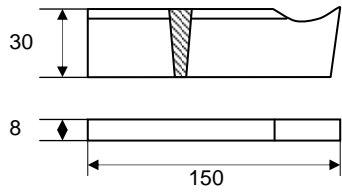
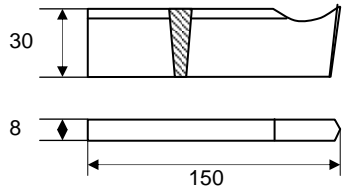
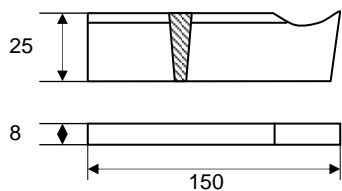
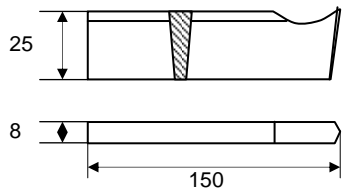
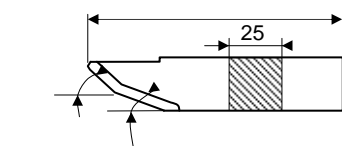
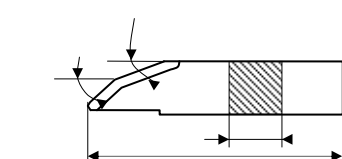
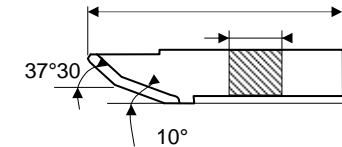
Rep.	Description	Machine	Maxi wall thickness	
O-TTN-TT15-8-H-PL	<i>Severing tool bit</i>	TTNG	90 mm 3.543"	
O-TTN-TT15-8-H-PT	<i>Cutting tool bit</i>	TTNG	90 mm 3.543"	
O-TTN-TT16-8-H-PL	<i>Severing tool bit</i>	TTNG	90 mm 3.543"	
O-TTN-TT16-8-H-PT	<i>Cutting tool bit</i>	TTNG	90 mm 3.543"	
O-TTN-TT17-25-H-17	<i>37°30' / 10° beveling tool bit for compound bevel</i>	TTNG	35 mm 1.378"	
O-TTN-TT171-25-H-17	<i>37°30' / 10° reversed compound beveling tool bit for double bevel</i>	TTNG	35 mm 1.378"	
O-TTN-TT18-25-H-18	<i>37°30' / 10° beveling tool bit for compound bevel</i>	TTNG	45 mm 1.771"	

PROTEM SAS ZI les Bosses F-26800 Etoile sur Rhone Tel.: +33 (0) 47557-4141 Fax: +33 (0) 47557-4149 www.protem.fr		  	PROTEM GmbH Am Hambiegel 27 D-76706 Dettenheim Tel.: +49 (0) 7247 9393-0 Fax: +49 (0) 7247 9393-33 www.protem-gmbh.de
ISO 9001	FT 00910	Toolbit TTNG	5/6

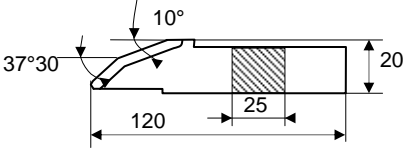
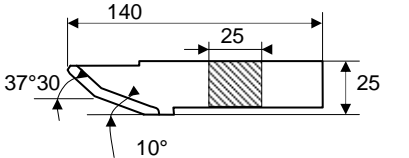
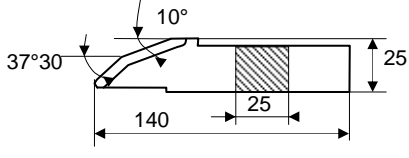
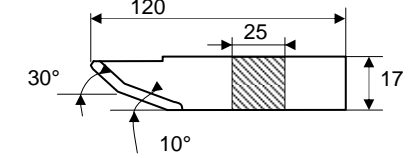
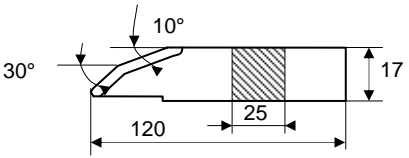
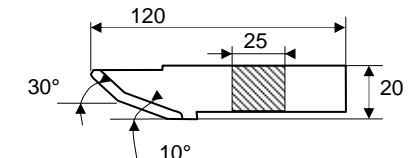
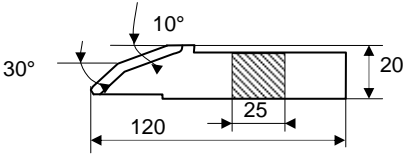
Rep.	Description	Machine	Maxi wall thickness	
O-TTN-TT18I-25-H-18	<i>37°30' / 10° reversed compound beveling tool bit for double bevel</i>	TTNG	45 mm 1.771"	
O-TTN-TT19-25-H-19	<i>37°30' / 10° beveling tool bit for compound bevel</i>	TTNG	50 mm 1.968"	
O-TTN-TT19I-25-H-19	<i>37°30' / 10° reversed compound beveling tool bit for double bevel</i>	TTNG	50 mm 1.968"	
O-TTN-TT20-25-H-20	<i>30° / 10° beveling tool bit for compound bevel</i>	TTNG	35 mm 1.378"	
O-TTN-TT20I-25-H-20	<i>30° / 10° reversed compound beveling tool bit for double bevel</i>	TTNG	35 mm 1.378"	
O-TTN-TT21-25-H-21	<i>30° / 10° beveling tool bit for compound bevel</i>	TTNG	45 mm 1.771"	
O-TTN-TT21I-25-H-21	<i>30° / 10° reversed compound beveling tool bit for double bevel</i>	TTNG	45 mm 1.771"	

PROTEM SAS ZI les Bosses F-26800 Etoile sur Rhone Tel.: +33 (0) 47557-4141 Fax: +33 (0) 47557-4149 www.protem.fr		  	PROTEM GmbH Am Hambiegel 27 D-76706 Dettenheim Tel.: +49 (0) 7247 9393-0 Fax: +49 (0) 7247 9393-33 www.protem-gmbh.de
ISO 9001	FT 00910	Toolbit TTNG	6/6

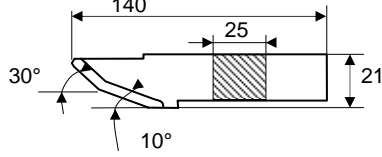
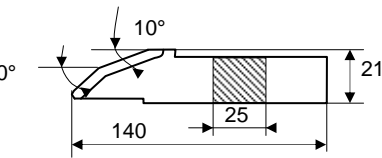
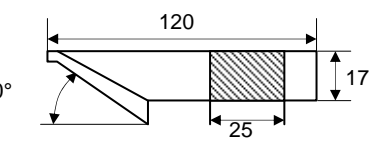
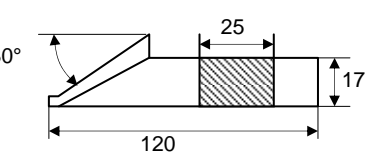
Rep.	Description	Machine	Maxi wall thickness	
O-TTN-TT22-25-H-22	<i>30° / 10° beveling tool bit for compound bevel</i>	TTNG	50 mm 1.968"	
O-TTN-TT22I-25-H-22	<i>30° / 10° reversed compound beveling tool bit for double bevel</i>	TTNG	50 mm 1.968"	
O-TTN-TT23-25-H-23	<i>30° beveling tool bit for double bevel</i>	TTNG	50 mm 1.968"	
O-TTN-TT23I-25-H-23	<i>30° reversed beveling tool bit for double bevel</i>	TTNG	50 mm 1.968"	
<i>Please consult us</i>	<i>Counterboring tool bit (all design)</i>	TTNG		